

# Installation and Operation Instructions

## Stone Age Amerigo™ and Mezzo™ Pizza Ovens



### 1.0 Introduction

The following provides instructions for the installation, operation and care of Stone Age Mezzo™ and Amerigo™ Pizza Ovens, manufactured by Stone Age Manufacturing, Collinsville, Oklahoma.

Three generations of wood-burning oven knowledge and experience have gone into the design, construction and use of these pizza ovens. A completed Amerigo oven, finished in rock and installed above a triple Amerigo cabinet unit, is shown in Figure 1.



Figure 1. Amerigo™ Pizza Oven

The only difference between the Amerigo and Mezzo ovens is size. Table 1 shows the components and dimensions of the two.

| Table 1<br>Amerigo/Mezzo Dimensions |           |        |
|-------------------------------------|-----------|--------|
| Size (In.)                          | Amerigo   | Mezzo  |
| Width                               | 48        | 36     |
| Depth                               | 42        | 33     |
| Height                              | 31        | 24     |
| Door opening                        | 25.5x12.5 | 15.5x8 |

This manual also provides instructions for the installation of the pizza oven base cabinet, an optional unit.

If installing the oven on something other than the base cabinet, make sure that it will support the weight of the oven.

### 2.0 Pizza Oven Components

Components for the Amerigo and Mezzo Pizza Ovens are shown in Figure 2.

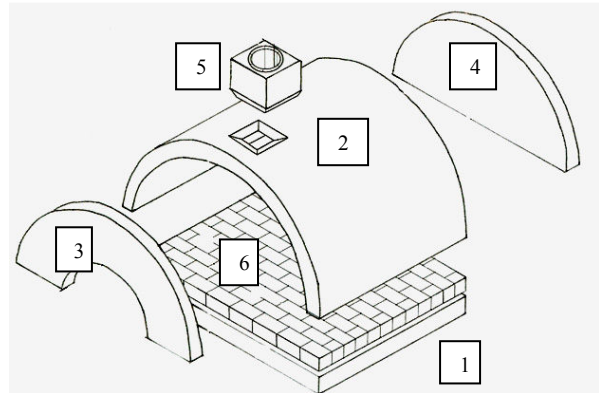

Figure 2. Pizza Oven Components

Components and part numbers are identified in Table 2. Item numbers in Table 2 correspond with the item numbers in Figure 2.

### 3.0 Safety

Working around an oven that can generate up to 800°F can be dangerous if proper clothing and tools are not used. Also, combustible materials in the vicinity of the oven may be at risk.

**WARNING: When working around a pizza oven, make sure that proper clothing is worn and proper tools are used. Make sure that combustible materials not necessary to baking pizza are kept away from the oven.**

| Table 2<br>Pizza Oven Components |            |     |                   |      |
|----------------------------------|------------|-----|-------------------|------|
| Amerigo™ Pizza Oven              |            |     | Mezzo™ Pizza Oven |      |
| Description                      | Part No.   | Qty | Part No.          | Qty. |
| Base Plate (1)                   | APO 1      | 1   | MPO 1             | 1    |
| Roof (2)                         | APO 2      | 1   | MPO 2             | 1    |
| Front Wall (3)                   | APO 3      | 1   | MPO 3             | 1    |
| Rear Wall (4)                    | APO 4      | 1   | MPO 4             | 1    |
| Chimney (5)                      | SAFLAPO    | 1   | SAFLAPO           | 1    |
| Door (Not shown)                 | SA-APOD-ML | 1   | SA-MPOD-ML        | 1    |
| Fire Brick (6)                   | SA-1006    | 50  | SA-1006           | 30   |

### 3.1 Clothing

A. It is advisable that long-sleeved shirts be worn when inserting and removing pizzas into/from the oven.

B. Use a non-combustible oven mitt when stoking and adding wood to the fire.

C. Use the non-combustible mitt when inserting and removing or turning pizzas.

### 3.2 Tools

Special tools are available for the management of oven fires and inserting and removing pizzas.

These tools can be obtained from Stone Age Manufacturing and are shown later in this manual.

### 4.0 Installation

The pizza ovens and associated base cabinets are not specifically designed as a “do it yourself” project. This is primarily because of component weight and the care required when applying mortar. However, it can be done if one has the necessary weight lifting equipment, and can use a mortaring trowel. We recommend that you contract with a professional mason or landscape contractor to install and finish your installation.

Although not included with the oven package, an optional base cabinet, used primarily for storage, is available from Stone Age Manufacturing. This manual includes procedures for installing both the oven and its base cabinet.

### 4.1 Installing the Base Cabinet

Like the pizza oven, the base cabinet is delivered as a kit, as shown in Figure 3. Each of the two pizza ovens has its own cabinet. Except for size, they are identical.

Tools required for this installation include a mallet or dead blow hammer, mason’s or rock hammer, masonry trowel, caulk gun and a power saw with masonry blades.

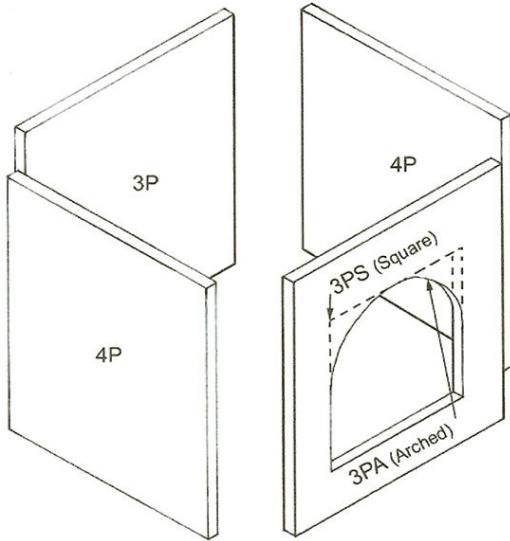

Figure 3. Base Cabinet Delivered

A 4-inch steel-reinforced concrete pad or patio should be constructed large enough to have an outside border to support finish material, if required. The pad should have piers below the frost line if required in your geographic location.

- A. Lay a chalk line on the pad to visualize the layout.
- B. Leave the foam shipping form in the front panel opening until the panel is in place.
- C. Arrange the panels as shown in Figure 4.

**WARNING: Each of the panels weighs about 200 pounds. Handle with extreme care with proper weight handling equipment.**



**Figure 4. Panel Arrangement**

Brackets, shown in Figure 5, are provided to hold the panels together and provide support.

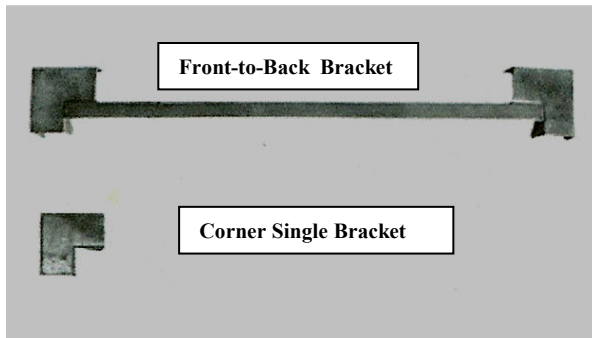

**Figure 5. Cabinet Brackets**

- D. At the back wall position of the box, place a corner single bracket (Figure 6) on the pad. These lower brackets may be glued if desired.
- E. Lay a 2-inch bead of Sonolastic® adhesive or a landscape block adhesive along a line where the panels will rest.

- F. Set the back panel (3P), shown in Figure 4, into the bracket as shown in Figure 6. Place all panels with the rough side out.



**Figure 6. Place Back Panel in Bracket**

- G. Place a side panel (4P) into the bracket, butting against the back panel. See Figure 7.



**Figure 7. Place Side Panel**

- H. Slide single corner bracket under the front end of panel 4P.
- I. Apply adhesive mortar between the two panels. Sonolastic adhesive is recommended.
- J. Install front panel into bracket, in front of panel 4P. Apply mortar between the two panels. Then, install a front-to-back bracket.

et, connecting the tree panels together, as shown in Figure 8.



**Figure 8. Install Front Panel**

- K. Install the other side panel in the same manner.
- L. Once the last front-to-back bracket is installed and all joints are mortared, the installation is complete, as shown in Figure 9.



**Figure 9. Installation Complete**

- M. Remove the foam shipping form from the front door opening. See Figure 4. Remove by sawing it out rather than knocking it out as the opening is susceptible to damage until the finish material has been applied.

#### 4.2 Installing the Pizza Oven

The base cabinet is installed and ready to receive the base for the pizza oven. If the base cabinet is not used, it is assumed that a satisfactory base surface has been prepared from concrete blocks or

other materials; is at the desired height, and will receive the weight of the pizza oven.

- A. Install the base plate on top of the base cabinet or other base you have selected. Check the level from front to back, side to side.
- B. Install firebrick from side to side using refractory mortar. Stone Age All Purpose Redi-Mix is recommended. See Figure 10.



**Figure 10. Install Firebrick on Baseplate**

- C. Figure 11 shows how the oven components go together. After the firebrick mortar sets up, lay a 2-inch bead of the same mortar along each side of the firebrick surface.

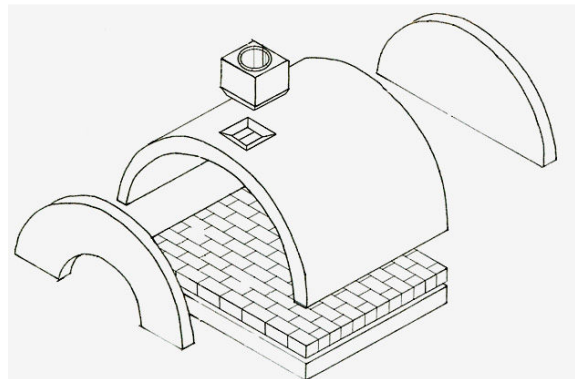

**Figure 11. Oven Components**

- D. Lift the roof and place it onto the firebrick. Because of the extreme weight of the roof, it is best to extend a beam under the roof and lift the beam from both ends with a person on each side to help guide the roof into position or lift with a machine. See Figure 12.

**WARNING: The roof of the pizza oven weighs 400 (Mezzo) to 600 (Amerigo) pounds. Be extremely**

careful in lifting. If dropped, it will easily chip and at the least, crack. Make sure you have sufficient help in lifting it.



**Figure 12. Install Roof**

- E. Inspect the mortared joint on both sides, inside and out and make sure it is smoothed out with no gaps.
- F. Install the chimney on top of the oven. Mortar inside as well as on top, as shown in Figure 13.



**Figure 13. Mortar Chimney Inside of Oven**

- G. Install the rear wall, using the same mortar. Carefully fill the joints with mortar, including the inside joints, as shown in Figure 14.



**Figure 14. Mortar Inside Joints**

- H. Install the front panel and carefully fill all joints with mortar, as shown in Figure 15.



**Figure 15. Install Front Wall**

Installation of the oven is now complete and ready for the outside finish to be installed. Brick, rock or any masonry/concrete compatible material can be used for the exterior finish, depending on your desires and the motif of your outside kitchen/patio. Two types of finish are shown in Figure 16.

As with any cooking appliance, heat transfer will occur from the inside cooking chamber to the outside walls of the oven. Thermal cycling can also cause expansion and contraction in the oven components and the mortar joints. This can be visible in the exterior veneer, especially in the mortar joints when it is applied directly to the surface of the oven and will vary on each application. These expansion and contraction cracks do not compromise the structural integrity of the oven and are only cosmetic. If the visibility of these hairline cracks is not desired, it is recommended that the

oven be encapsulated with concrete block, metal framing with concrete board attached or surrounded with other non-combustible material. If this method is used, leave a minimum of 3 inches of air space between the encapsulating walls and oven unit. This space can be left void or filled with insulating materials like perlite or vermiculite to further insulate and stop any heat transfer. The outside profile of the oven can be changed to create any shape or architectural design when using this method.

Another option is to cover the oven with a ceramic fiber blanket wrapped with metal lathe and scratch coated with cement before applying veneer materials.



Amerigo™ Pizza Oven



Mezzo™ Pizza Oven

Figure 16. Pizza Oven Finishes

## 5.0 Building a Fire

The owner should wait a minimum of 28 days after construction is completed to build the first fire. It is important that all moisture be gone from the oven before the first fire is laid. After that, the first three fires should be small to gently season and break in the oven.

Failure to allow full curing of the mortar may result in expansion cracking in the oven's mortar joints and finish. This is not a structural defect and does not harm the product integrity, but may affect the appearance.

In order to reduce the possibility of moisture collection, it is recommended that the ovens exterior veneer be treated with a water sealer after completion of the exterior.

**WARNING: Do not start a fire in a unit that has been exposed to excessive moisture.**

To protect from moisture, keep the oven door in place and cover the chimney when the oven is not in use.

### 5.1 Selection of Wood

Any cured wood that is suitable for smoking meats can be used in pizza ovens. Hickory, pecan and mesquite wood are good. Oak is good for heating ovens and generating a bed of coals. Flavored wood such as apple and cherry fruitwoods, soaked in water, can be used for smoking when the cooking starts.

Charcoal and natural lump charcoal are also an option for cooking along with fruitwood chips for flavor.

Avoid use of green uncured wood as it will have a much stronger smoke flavor which can be overbearing, and will produce more soot and oils.

*Caution: Do not use paper, trash, synthetic logs, or wood treated with petroleum or other chemicals.*

### 5.2 Starting and Keeping a Fire

It takes time and experience to learn the nature of a wood-fired oven. There are a lot of variables affecting cooking such as type and quantity of wood, ambient temperature, size of oven and the dish being cooked.

Recommended length of wood sticks is 6-12 inches for the Mezzo oven 6-18 inches for the Amerigo. Stores selling BBQ supplies will have smoking wood in chunks or cut smaller for smokers and wood fired ovens.

Just like the oven inside your home or an outdoor gas cooking appliance a wood fired oven will require a certain amount of cleaning and maintenance after usage.

By design the chimney flue of wood fired ovens are undersized for maximum heat retention. This will cause smoke spillage out of the front of the oven opening and leave soot, creosote or smoke stains on the face of the ovens exterior. This spillage and staining is common on all brands of wood-fired ovens without power vented chimneys. The degree of staining will vary depending type of wood used for cooking, how cured the wood is, amount and length of usage, wind direction and speed along with several other factors that will

vary with each application. This adds character and gives an authentic old world appearance to your oven but the staining can easily be removed with a wire brush and water or by using a masonry cleaning solution for soot and smoke that can be purchased at most hardware stores, home improvement stores, specialty fireplace retailers or on the internet.

Fire management tools are shown in Figure 17.



**Figure 17. Fire Management Tools**

The sequence for building a fire is as follows:

- Build a fire in the center of the oven floor and develop a good bed of coals. The size will depend on what is to be cooked and the quantity.
- Heat the oven to 350° to 600°F. This may take as much as two hours. Heating above 800°F is not recommended.
- When desired temperature is reached, push the fire and coals to the rear and sides of the oven. Sweep fine ashes to the sides and back of the oven using a wire ash brush. Use one of the tools shown in Figure 14.
- Insert pizzas and cook directly on the oven floor.
- Add wood as necessary to maintain desired temperature. If cooking several pizzas, it may be necessary to pull the fire back to the middle to reheat the floor and repeat the process.

### 5.3 Cooking

If the oven has been exposed to moisture 48 hours prior to use, build a small fire and heat the oven to 250-300°F for two hours before increasing the heat to cooking temperature. An easy solution is to burn an 8-10 pound bag of match lite charcoal and let it burn completely. This will slowly dry out the moisture that the oven has absorbed.

As stated, we recommend cooking in a temperature range of 350° to 600°F. Time of cooking will depend on the temperature and the item being cooked. The floor is the heat source that will do

most of the cooking. An infra-red temperature gauge like that shown in Figure 18 can be used to measure temperature at any location in and around the oven.

Cooking pizza in a wood-fired oven is somewhat like grilling or smoking meats in that there are many variables such as the type of wood used, ambient temperature and humidity, oven temperature and thickness of crust and toppings, that affect the outcome. Be prepared to spend a few times testing recipes and techniques. Practice and experimentation will show how to best cook your favorite style of pizza.

- A traditional Italian pizza with a thick crust and a thin layer of toppings should cook at 600°F or hotter for 3-6 minutes.
- For thicker pizzas with heavier toppings, lower temperatures are required to thoroughly cook without burning.
- A medium pizza with heavy toppings may cook best at 400°F-500°F and will require a longer cooking times, perhaps 15-25 minutes.

Cook the pizza directly on the floor of the oven. Place it in the oven using a long-handled paddle called a peel, using hot mitts or hot pads. Slide the pizza from the preparation surface to the peel, and then onto the cooking surface using a slight jerking technique.

**WARNING: Be mindful of the hot surfaces of your pizza oven. Because of the high temperatures, extra caution should be used when cooking with a wood-fired oven. Use proper, long-handled tools and protective mitts when working around the opening or reaching into the hot oven.**

Tools required for cooking pizza are shown in Figure 18 and are available from Stone Age Manufacturing.



Figure 18. Cooking Tools

## 6.0 Cleaning, Inspection and Maintenance

As is the case with most other equipment, cleanliness is the best maintenance practice and will contribute to many hours use.

**WARNING: Do not clean the oven when it is hot.**

Let the fire and coals completely burn out and cool before cleaning. It is best to wait until the

next day before removing ashes.. Ashes should be placed in a metal container with a tight-fitting lid, and removed from all combustible materials, pending final disposal. If the ashes are disposed of by burial in soil or otherwise locally dispersed, they should be retained in the closed container until all cinders have thoroughly cooled.

Spot check the refractory bricks and mortar for small cracks. It will expand slightly with the heat, then contract as it cools. Replace refractory bricks when the cracks open more than 1/4"; or when pits become extensive and deeper than 3/16" when oven is at ambient temperature and not in use; or when any piece of refractory larger than 2 inches in diameter becomes dislodged.

If creosote has accumulated, it should be removed to reduce the risk fire. Remove creosote using a wire brush and/or a creosote liquid detergent designed for this purpose. Also there are manufactured logs available that are designed for the removal of creosote. These products will be available at most local hardware stores, home improvement stores, specialty fireplace retailers or on the internet.

Keep the door in place and a cap on the chimney when not in use to protect the interior cooking chamber of the oven from exposure to moisture.



### **LIMITED WARRANTY**

The products of Stone Age Manufacturing, Inc. (“Stone Age”) have been carefully manufactured and the components assembled to give the customer a quality product. Stone Age warrants to the original purchaser the materials that it provides to the customer against defects in manufacture for a period of twenty-five (25) years from the date of purchase on UL-127 listed fireplaces, for a period of five (5) years from the date of purchase on all unlisted fireplaces, fire pits, and other masonry components. Other accessory items or components offered, but not produced by Stone Age Manufacturing, Inc., shall be covered by their manufacturer’s warranties. This Limited Warranty covers only actual manufacturing defects in the Stone Age product and does not cover defects or faulty workmanship in the installation of the product or the masonry or other structure in which it is installed. Also this warranty does not cover items that have been damaged due to over-heating, modification, improper storage or maintenance. Stone Age shall repair or replace, at its option, any defective Stone Age product component upon receipt of written notice addressed to Stone Age. This Limited Warranty covers only replacement of any defective components within the product itself occurring during the warranty period and does not cover the cost of installation or removal from a fixed location. NO OTHER WARRANTIES, EXPRESS OR IMPLIED, ARE MADE, INCLUDING IMPLIED WARRANTIES OF MERCHANTABILITY AND FITNESS FOR PARTICULAR PURPOSES WHICH ARE SPECIFICALLY DISCLAIMED. Stone Age is not liable for damages or injury to persons or property or other incidental or consequential damages.

Stone Age Manufacturing, Inc.  
11107 E. 126<sup>th</sup> St. N., Collinsville, OK 74021  
[WWW.Stoneagefireplaces.com](http://WWW.Stoneagefireplaces.com)

Sonolastic® is a registered trademark of BASF Chemical Company